



FG250S

Grinder

Description

The FG250S is a single-phase mono disc surface grinder with versatile functionality and foldable design for easy transport and storage.

Article code Power

800196	115 V / 60 Hz, 1,1 kW / 1.5 HP
800197	115 V / 50 Hz, 1,5 kW / 1.5 HP

Technical data

Working width	250 mm / 10"
Rotating speed	1410 rpm
Weight	52 Kg / 115 lbs
Hose connection	50 mm / 2"

Pairs with

Dust extractor **S2**



Key features

- Foldable handle with quick handgrip
- Water connection
- Large wheels
- Floating dust shroud
- Suitable for small areas
- Handles quick fix grinding tasks
- Convertible to edge grinder with quick adjustment
- Compatible with multiple disc types for different surfaces
- Portable (fits in smaller vehicles)

Rotating tool



Foldable handle



Leveling tool



Water cooling

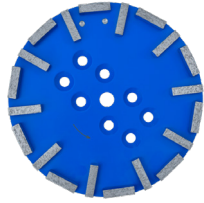
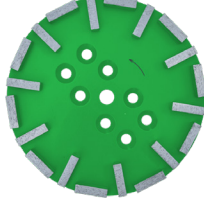
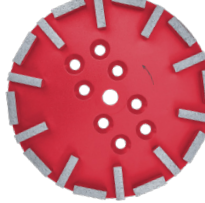

SPARE PARTS

20 segments diamond disks		
900964 - Soft concrete and screed	900965 - Medium concrete	900966 - Hard concrete
		

16 segments diamond disk
900971 - PCD disc
