



# FG250S

## Grinder

### Description

The FG250S is a single-phase mono disc surface grinder with versatile functionality and foldable design for easy transport and storage.

### Article code

### Power

800195

230 V / 50 Hz, 2.2 kW / 3 HP

### Technical data

Working width 250 mm / 10"

Rotating speed 1410 rpm

Weight 52 Kg / 115 lbs

Hose connection 50 mm / 2"

### Pairs with

Dust extractor S2



### Key features

Foldable handle with quick handgrip

Water connection

Large wheels

Floating dust shroud

Suitable for small areas

Handles quick fix grinding tasks

Convertible to edge grinder with quick adjustment

Compatible with multiple disc types for different surfaces

Portable (fits in smaller vehicles)

Rotating tool



Foldable handle



Leveling tool



Water cooling

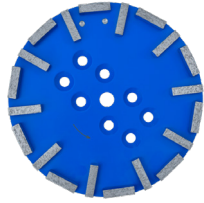
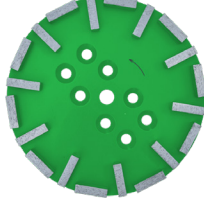
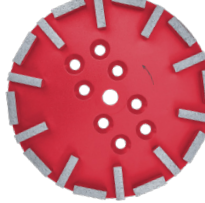

# SPARE PARTS

20 segments diamond disks		
900964 - Soft concrete and screed	900965 - Medium concrete	900966 - Hard concrete
		

16 segments diamond disk
900971 - PCD disc
